

PV-SERIES



22000 - 30000 LBS.

SPECIFICATIONS



▶ PV220-300

CLASS
5

INTERNAL COMBUSTION ENGINE PNEUMATIC TIRE

HoistLift.com

CAPACITY 22000 – 30000 LBS.	MAXIMUM FORK HEIGHT 244 IN.	LOAD CENTER 24 IN.
--	--	-------------------------------------

INDUSTRIES



Lumber



Steel/Metals



Concrete



General Manufacturing



Brick, Block & Pipe



Mining



Oil & Gas

STANDARD FEATURES

DURABILITY

- Force-cooled wet disc brakes
- Heavy-duty planetary drive axle rated for high-capacity, off-road applications
- Rigidly constructed welded frame
- Engine protection system
- High-capacity cooling system
- Open-core radiator with fan shroud
- Welded-nested mast rails
- Pin-type forks
- Two-stage heavy-duty air cleaner
- Wide visible 2-stage mast (V)
- 24-Volt electrical system with two 12V batteries

SUPPORT

- Electrical horn
- Asbestos-free components
- Neutral safety switch
- Integrated overhead guard
- Operator Restraint System seat
- Orange forks
- Operator Presence Sensing System (OPSS)

PERFORMANCE

- CUMMINS® 4.5-liter Tier 4 Final diesel engine (4-cylinder)
 - Common-rail electronic fuel injection system
 - Turbocharged & intercooled
 - Self-regenerating DPF
 - SCR (Selective Catalytic Reduction)
- Dana TE-10 electronically controlled powershift transmission
- 7" touch-screen multi-function display
 - All gauges/instrumentation/warning lights
 - Controls for work lights, wipers, heat, air conditioning, and radio controls
 - Electronic diagnostics with fault code history
 - Reference library
 - Measurement, adjustment, and preference menus
- Full hydraulic power steering
- Dual pump "full flow", on-demand load sensing hydraulic system
- 2-function hydraulic control valve (lift & tilt)
- Independent brake & inching pedals
- Upswept exhaust

ERGONOMICS/CABIN

- Front and rear reflectors
- Mechanical suspension seat
- Telescopic and tilting steering column
- Floor mat
- Operator manual box
- Roof-mounted amber strobe
- Fingertip hydraulic controls
- Left-hand shift lever
- Long operator assist grips
- Spring-applied/hydraulic-release parking brake
- Standard premium cabin
 - Cup holder(s)
 - Enclosed cab with doors
 - Front, rear, and top wipers
 - Heat/defrost
 - Air conditioning
 - Operator fan
 - Dome light
 - Front LED work lights (2)
 - Rear work light
 - Stop/turn/tail combination lights
- Front turn signal lights (2)
- Aux 12V power supply
- USB charging port(s)
- Top and rear sunshades
- Rearview mirror
- AM/FM/MP3 radio with 2 speakers

SERVICEABILITY

- Remote oil drain
- Easy-access filters
- Easy-lift hoods, panels, and doors
- Externally serviceable brakes
- Cab tilt with manual handpump

OPTIONAL EQUIPMENT

POWERTRAIN

- Fuel cap, locking
- Password protected operation
- Auto shutdown timer
- Speed limiting, loaded
- Speed limiting, loaded and unloaded

CARRIAGE

- Sideshifter
- Fork positioner (dependant)
- Fork positioner (independent)
- SS/FP (dependant)
- SS/FP (independent)
- Various load backrest heights
- Tilt indicator, mechanical

TIRE/WHEEL

- Pneumatic - lugged, radial
- Pneumatic - lugged, radial, XZM
- Solid pneumatic

COLD START AID

- Engine block heater
- Engine pad warmer

CAB/CONTROLS

- Open cab
- Value cab
- Air ride suspension seat

INDICATORS & MISC.

- Forward camera system visibility aid
- Rear camera system visibility aid
- Dual camera system visibility aid
- Overload warning indicator
- Onboard load weighing system
- Fire extinguisher (5 lb. cab mount)
- Rear object detection radar
- Shock sensor warning system (with logging)
- Tire pressure monitoring system
- French Canadian language

HYDRAULIC

- Lift accumulator
- Tilt accumulator

ELECTRICAL

- Jumpstart receptacle (studs)
- Jumpstart receptacle (NATO)
- Lockable battery isolator

LIGHTS/ALARMS

- Extra work lights - LED rear facing (pair)
- Extra work lights - LED mast mount (pair)
- Extra work lights - LED fender mount (pair)
- Backup alarm
- Backup alarm (smart)
- Travel alarm (bi-directional)
- Horn, 24V, 110dB
- Horn, trumpet, 24V, 118dB
- Blue LED spot light, forward facing
- Blue LED spot light, rear facing

SERVICE/MAINTENANCE

- Cab tilt, powered with backup manual hand pump
- Front lift plate

PAINT (REQUIRES PAINT CODE & MAP)

- Custom color (single)
- Intermodal tire striping
- Chevron striping on counterweight

TRUCK SPECIFICATIONS

MODEL NUMBERS

MODEL			PV220	PV240	PV260	PV280	PV300	
Load Capacity	lb (kg)		22000 (9979)	24000 (10890)	26000 (11790)	28000 (12700)	30000 (13610)	
Load Center	in (mm)		24 (610)	24 (610)	24 (610)	24 (610)	24 (610)	
Brakes (service foot / parking)			Wet Disc / Caliper (Disc)					
Transmission	Type		PowerShift					
	Speeds (fwd. / rev.)	mph	3 / 3					
Internal Combustion Engine	Make / Model		CUMMINS 4.5L					
	Rated Horsepower @ rpm	SAE HP (kW)	173 @ 2500 (129 @ 1500)	173 @ 2500 (129 @ 1500)	173 @ 2500 (129 @ 1500)	173 @ 2500 (129 @ 1500)	173 @ 2500 (129 @ 1500)	
	Rated Torque @ rpm	SAE ft-lb (N-m)	520 @ 1500 (705 @ 1500)	520 @ 1500 (705 @ 1500)	520 @ 1500 (705 @ 1500)	520 @ 1500 (705 @ 1500)	520 @ 1500 (705 @ 1500)	
Battery	Voltage	V	24	24	24	24	24	
EXTERIOR DIMENSIONS			PV220	PV240	PV260	PV280	PV300	
A	Mast Extended Height	in (mm)	199.37 (5064)	199.37 (5064)	199.37 (5064)	199.37 (5064)	199.37 (5064)	
B	Mast Lowered Height	in (mm)	128 (3251)	128 (3251)	128 (3251)	128 (3251)	128 (3251)	
C	Maximum Fork Height (MFH) (top of forks)	in (mm)	138 (3505)	138 (3505)	138 (3505)	138 (3505)	138 (3505)	
D	Load Distance ¹	in (mm)	30.70 (779)	30.95 (786)	30.95 (786)	31.20 (792)	31.20 (792)	
E	Wheelbase	in (mm)	115 (2921)	115 (2921)	115 (2921)	115 (2921)	115 (2921)	
F	Fork Size (T x W x L)	in (mm)	2.5 (64) / 8 (203) / 48 (1219)	2.75 (70) / 8 (203) / 48 (1219)	2.75 (70) / 8 (203) / 48 (1219)	3 (76) / 8 (203) / 48 (1219)	3 (76) / 8 (203) / 48 (1219)	
G	Length to Fork Face	in (mm)	180.08 (4574)	180.33 (4580)	180.33 (4580)	180.58 (4587)	180.58 (4587)	
H	Overhead Guard Clearance	in (mm)	133.41 (3388)	133.41 (3388)	133.41 (3388)	133.41 (3388)	133.41 (3388)	
I	Tilt Range (forward / backward)	deg	15 / 12	15 / 12	15 / 12	15 / 12	15 / 12	
J	Outside Turning Radius	in (mm)	163.53 (4154)	163.53 (4154)	163.53 (4154)	163.53 (4154)	163.53 (4154)	
K	Basic Right-Angle Stacking Aisle Width ²	in (mm)	194.23 (4933)	194.48 (4940)	194.48 (4940)	194.73 (4946)	194.73 (4946)	
L	Overall Width	in (mm)	98.09 (2491)	98.09 (2491)	98.09 (2491)	98.09 (2491)	98.09 (2491)	
M	Tread Width	Front	in (mm)	71.90 (1826)	71.90 (1826)	71.90 (1826)	71.90 (1826)	
		Rear	in (mm)	79.74 (2025)	79.74 (2025)	79.74 (2025)	79.74 (2025)	
N	Underclearance (full load)	Minimum with Load	in (mm)	9.56 (243)	9.56 (243)	9.56 (243)	9.56 (243)	
		Center of Wheelbase	in (mm)	13.5 (343)	13.5 (343)	13.5 (343)	13.5 (343)	
PERFORMANCE DATA			PV220	PV240	PV260	PV280	PV300	
Speeds	Maximum Travel (forward / reverse)	Full Load	mph (km/h)	17.9 (28.8) / 17.9 (28.8)	17.9 (28.8) / 17.9 (28.8)	17.9 (28.8) / 17.9 (28.8)	17.9 (28.8) / 17.9 (28.8)	17.9 (28.8) / 17.9 (28.8)
		No Load	mph (km/h)	19.0 (30.5) / 19.0 (30.35)	19.0 (30.5) / 19.0 (30.35)	19.0 (30.5) / 19.0 (30.35)	19.0 (30.5) / 19.0 (30.35)	19.0 (30.5) / 19.0 (30.35)
	Lifting	Full Load	fpm (mm/sec)	87 (442)	87 (442)	87 (442)	87 (442)	87 (442)
		No Load	fpm (mm/sec)	92 (467)	92 (467)	92 (467)	92 (467)	92 (467)
	Lowering	Full Load	fpm (mm/sec)	92 (467)	92 (467)	92 (467)	92 (467)	92 (467)
		No Load	fpm (mm/sec)	88 (447)	88 (447)	88 (447)	88 (447)	88 (447)
FUEL CAPACITY			PV220	PV240	PV260	PV280	PV300	
Fuel Tank	US gal (L)		31 (117)	31 (117)	31 (117)	31 (117)	31 (117)	
TRUCK WEIGHTS			PV220	PV240	PV260	PV280	PV300	
Gross Weight (empty)	lb (kg)		37770 (17132)	38314 (17379)	38776 (17588)	39627 (17974)	39819 (18062)	
Weight Distribution	Front - Full Load	lb (kg)	52157 (23644)	55161 (25021)	58020 (26317)	61194 (27757)	63880 (28975)	
	Rear - Full Load	lb (kg)	7613 (3453)	7153 (3245)	6756 (3064)	6430 (2917)	5939 (2694)	
	Front - No Load	lb (kg)	19693 (8933)	19693 (8933)	19597 (8889)	19754 (8960)	19480 (8836)	
	Rear - No Load	lb (kg)	18077 (8199)	18621 (8446)	19597 (8889)	19870 (9013)	20339 (9226)	
ATTACHMENT			PV220	PV240	PV260	PV280	PV300	
Auxiliary Hydraulic Function (for attachments)	Max. Operating Pressure	psi (kg/cm ²) (MPa)	2700 (190) (18.6)	2700 (190) (18.6)	2700 (190) (18.6)	2700 (190) (18.6)	2700 (190) (18.6)	
	Max. Flow Rate	gpm	25	25	25	25	25	
TIRES			PV220	PV240	PV260	PV280	PV300	
Type (front / rear)			Pneumatic / Pneumatic					
Number	Front / Rear		4 / 2					
Size	Front		10.00-20 16PR	10.00-20 16PR	10.00-20 16PR	10.00-20 16PR	10.00-20 16PR	
	Rear		10.00-20 16PR	10.00-20 16PR	10.00-20 16PR	10.00-20 16PR	10.00-20 16PR	

1 Centerline of front axle to front face of forks.
 2 Add load length & aisle clearance.

EXTERIOR DIMENSIONS

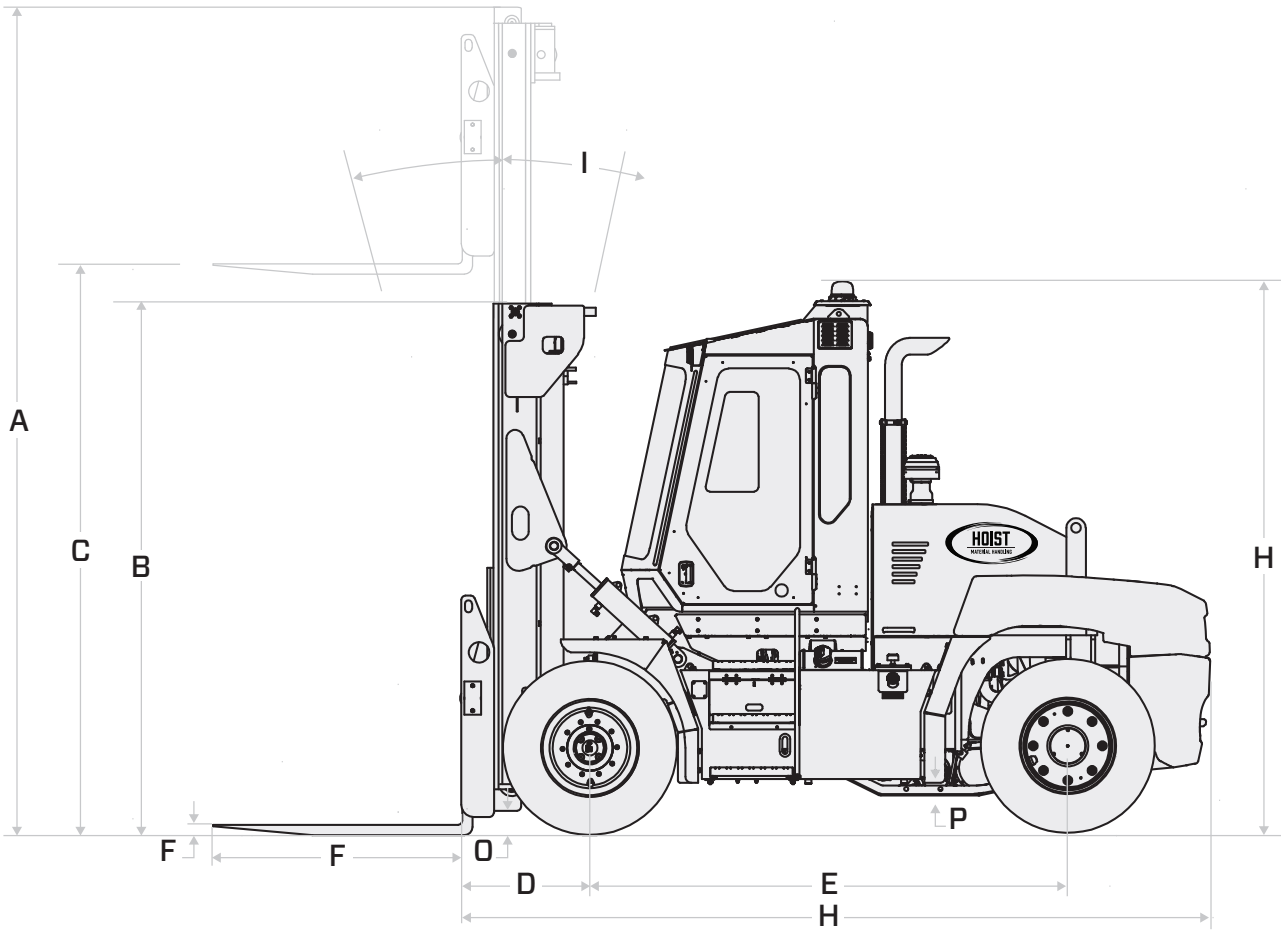
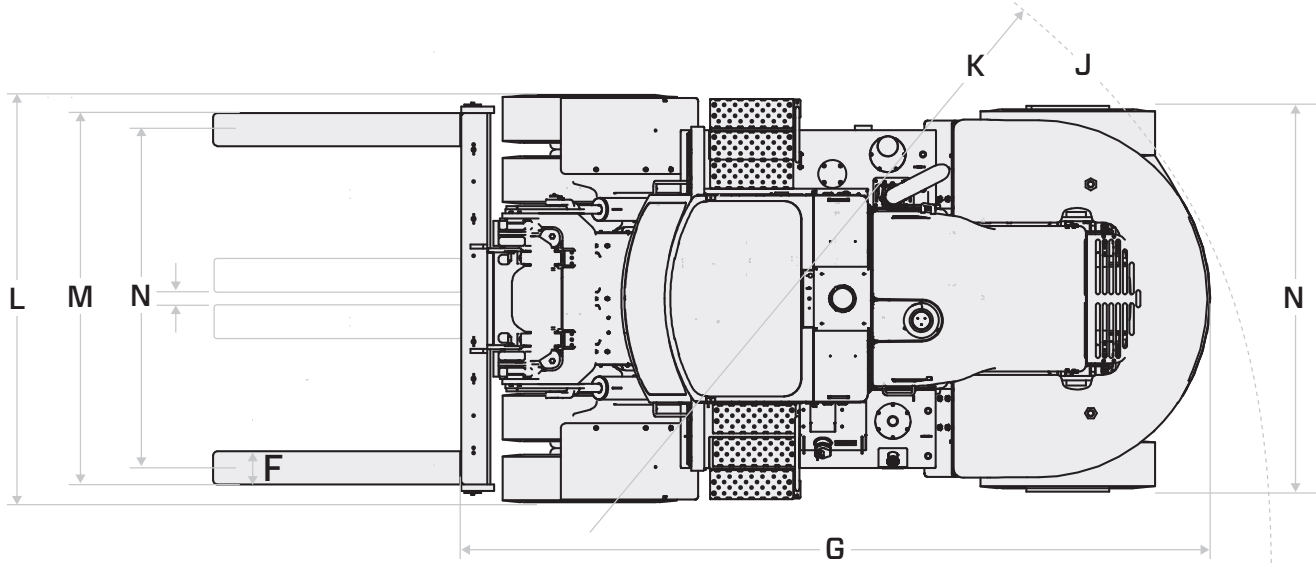

MAST SPECIFICATIONS

MAST TYPE	MAXIMUM FORK HEIGHT (TOP OF FORKS)	OVERALL HEIGHT LOWERED	FREE- LIFT	TILT RANGE		LOAD CAPACITY AT		
				FWD	BWD	24 IN. (610 MM) LOAD CENTER 2.75" x 8" x 48" (STD.) FORKS	36 IN. (900 MM) LOAD CENTER 2.75" x 8" x 72" (OPT.) FORKS	48 IN. (1220 MM) LOAD CENTER 2.75" x 8" x 96" (OPT.) FORKS
				deg	deg	lb (kg)	lb (kg)	lb (kg)
PV220								
Wide Visible (V)	138 (3505)	128 (3251)	0	15	12	22000 (9979)	18167 (8240)	14200 (6441)
	154 (3912)	136 (3454)	0	15	12	22000 (9979)	18167 (8240)	14200 (6441)
	174 (4419)	146 (3708)	0	15	12	22000 (9979)	18167 (8240)	14200 (6441)
	194 (4927)	156 (3962)	0	15	12	22000 (9979)	18167 (8240)	14200 (6441)
	204 (5182)	166 (4216)	0	15	12	22000 (9979)	18167 (8240)	14200 (6441)
	224 (5690)	176 (4470)	0	15	12	22000 (9979)	18167 (8240)	14200 (6441)
	244 (6198)	186 (4724)	0	15	12	22000 (9979)	18167 (8240)	14200 (6441)

MAST TYPE	MAXIMUM FORK HEIGHT (TOP OF FORKS)	OVERALL HEIGHT LOWERED	FREE- LIFT	TILT RANGE		LOAD CAPACITY AT		
				FWD	BWD	24 IN. (610 MM) LOAD CENTER 2.75" x 8" x 48" (STD.) FORKS	36 IN. (900 MM) LOAD CENTER 2.75" x 8" x 72" (OPT.) FORKS	48 IN. (1220 MM) LOAD CENTER 2.75" x 8" x 96" (OPT.) FORKS
				deg	deg	lb (kg)	lb (kg)	lb (kg)
PV240								
Wide Visible (V)	138 (3505)	128 (3251)	0	15	12	24000 (10890)	19818 (8989)	16400 (7439)
	154 (3912)	136 (3454)	0	15	12	24000 (10890)	19818 (8989)	16400 (7439)
	174 (4419)	146 (3708)	0	15	12	24000 (10890)	19818 (8989)	16400 (7439)
	194 (4927)	156 (3962)	0	15	12	24000 (10890)	19818 (8989)	16400 (7439)
	204 (5182)	166 (4216)	0	15	12	24000 (10890)	19818 (8989)	16400 (7439)
	224 (5690)	176 (4470)	0	15	12	24000 (10890)	19818 (8989)	16400 (7439)
	244 (6198)	186 (4724)	0	15	12	24000 (10890)	19818 (8989)	16400 (7439)

MAST TYPE	MAXIMUM FORK HEIGHT (TOP OF FORKS)	OVERALL HEIGHT LOWERED	FREE- LIFT	TILT RANGE		LOAD CAPACITY AT		
				FWD	BWD	24 IN. (610 MM) LOAD CENTER 2.75" x 8" x 48" (STD.) FORKS	36 IN. (900 MM) LOAD CENTER 2.75" x 8" x 72" (OPT.) FORKS	48 IN. (1220 MM) LOAD CENTER 2.75" x 8" x 96" (OPT.) FORKS
				deg	deg	lb (kg)	lb (kg)	lb (kg)
PV260								
Wide Visible (V)	138 (3505)	128 (3251)	0	15	12	26000 (11790)	21470 (9738)	16400 (7439)
	154 (3912)	136 (3454)	0	15	12	26000 (11790)	21470 (9738)	16400 (7439)
	174 (4419)	146 (3708)	0	15	12	26000 (11790)	21470 (9738)	16400 (7439)
	194 (4927)	156 (3962)	0	15	12	26000 (11790)	21470 (9738)	16400 (7439)
	204 (5182)	166 (4216)	0	15	12	26000 (11790)	21470 (9738)	16400 (7439)
	224 (5690)	176 (4470)	0	15	12	26000 (11790)	21470 (9738)	16400 (7439)
	244 (6198)	186 (4724)	0	15	12	26000 (11790)	21470 (9738)	16400 (7439)

MAST TYPE	MAXIMUM FORK HEIGHT (TOP OF FORKS)	OVERALL HEIGHT LOWERED	FREE- LIFT	TILT RANGE		LOAD CAPACITY AT		
				FWD	BWD	24 IN. (610 MM) LOAD CENTER 3" x 8" x 48" (STD.) FORKS	36 IN. (900 MM) LOAD CENTER 3" x 8" x 72" (OPT.) FORKS	48 IN. (1220 MM) LOAD CENTER 3" x 8" x 96" (OPT.) FORKS
				deg	deg	lb (kg)	lb (kg)	lb (kg)
PV280								
Wide Visible (V)	138 (3505)	128 (3251)	0	15	12	28000 (12700)	23121 (10487)	19000 (8618)
	154 (3912)	136 (3454)	0	15	12	28000 (12700)	23121 (10487)	19000 (8618)
	174 (4419)	146 (3708)	0	15	12	28000 (12700)	23121 (10487)	19000 (8618)
	194 (4927)	156 (3962)	0	15	12	28000 (12700)	23121 (10487)	19000 (8618)
	204 (5182)	166 (4216)	0	15	12	28000 (12700)	23121 (10487)	19000 (8618)
	224 (5690)	176 (4470)	0	15	12	28000 (12700)	23121 (10487)	19000 (8618)
	244 (6198)	186 (4724)	0	15	12	28000 (12700)	23121 (10487)	19000 (8618)

MAST TYPE	MAXIMUM FORK HEIGHT (TOP OF FORKS)	OVERALL HEIGHT LOWERED	FREE- LIFT	TILT RANGE		LOAD CAPACITY AT		
				FWD	BWD	24 IN. (610 MM) LOAD CENTER 3" x 8" x 48" (STD.) FORKS	36 IN. (900 MM) LOAD CENTER 3" x 8" x 72" (OPT.) FORKS	48 IN. (1220 MM) LOAD CENTER 3" x 8" x 96" (OPT.) FORKS
				deg	deg	lb (kg)	lb (kg)	lb (kg)
PV300								
Wide Visible (V)	138 (3505)	128 (3251)	0	15	12	30000 (13610)	24773 (11237)	19000 (8618)
	154 (3912)	136 (3454)	0	15	12	30000 (13610)	24773 (11237)	19000 (8618)
	174 (4419)	146 (3708)	0	15	12	30000 (13610)	24773 (11237)	19000 (8618)
	194 (4927)	156 (3962)	0	15	12	30000 (13610)	24773 (11237)	19000 (8618)
	204 (5182)	166 (4216)	0	15	12	30000 (13610)	24773 (11237)	19000 (8618)
	224 (5690)	176 (4470)	0	15	12	30000 (13610)	24773 (11237)	19000 (8618)
	244 (6198)	186 (4724)	0	15	12	30000 (13610)	24773 (11237)	19000 (8618)



HOIST

**⚠ DANGER
STAY CLEAR**

⚠ DANGER
Vehicle moves
with forks
STAY CLEAR

⚠ DANGER
Vehicle moves
with forks
STAY CLEAR



Hoist Material Handling, Inc.
4407 Railroad Ave. | East Chicago, IN 46312
www.Hoistlift.com | 708-458-2200 | Sales@hoistlift.com

WARRANTY SERVICES
812-359-1171 | Warrantyservices@hoistlift.com

AFTERMARKET PARTS
708-458-2200 | Parts@hoistlift.com

Some product features described are optional.
Please consult your dealer for specifications. Details of specifications and equipment are based on information
available at time of printing and may change without notice.